

## RV Toilet Service Parts for Aria CLASSIC

### Mechanism Blade Seal

#### Tools Needed

- 7/16" wrench
- Adjustable wrench
- Flat-blade screwdriver
- Phillips screwdriver
- Short Phillips screwdriver
- Pliers
- Towels

#### Note

- Read all instructions before beginning work.
- Avoid contact with human waste by wearing protective items such as gloves, glasses, long sleeves and nose/face mask. Wash toilet area you will be working on.
- To reduce holding tank odor: Rinse toilet with at least 1 gallon of water. Drain Holding Tank. Add appropriate dose of Thetford Holding Tank Deodorant.

#### Remove Toilet

1. Turn off RV water supply per RV Owner's Manual.
2. Pry off Bolt Caps with flat-blade screwdriver. Use wrench to remove 7/16 -inch Lag Screws.
3. Disconnect Water Supply Line with adjustable wrench.
4. Place an old towel or soft cloth on work surface. Remove Toilet from floor and place upside down, with back facing you, on work surface. Instructions below (left, right, etc.) will assume this orientation.
5. Remove old Closet Flange Seal (may be found in Toilet or in floor at Closet Flange). Discard.
6. Cover Holding Tank opening to contain odor.

#### To Remove Blade Seal

1. Loosen Clamp closest to Mechanism to remove Mounting Flange, Mounting Bushings, Outfall Tube (high-profile units only) and Hub Seal (Fig. A).
2. Using Phillips screwdriver, remove three screws (without washers) attaching Mechanism to Mechanism Plate (Fig. B).
3. Using short Phillips screwdriver, remove Standoff Screw securing Mechanism to Mechanism Plate (Fig. C, lower).
4. Disengage left-side Cable Sheath Fitting from Mechanism Plate (Fig. C, lower).
5. Lift Mechanism out, turn it over, and pull Blade Seal out of groove in bowl side of opening.

#### To Install New Blade Seal

1. Install new Blade Seal in Mechanism so that it snaps into the

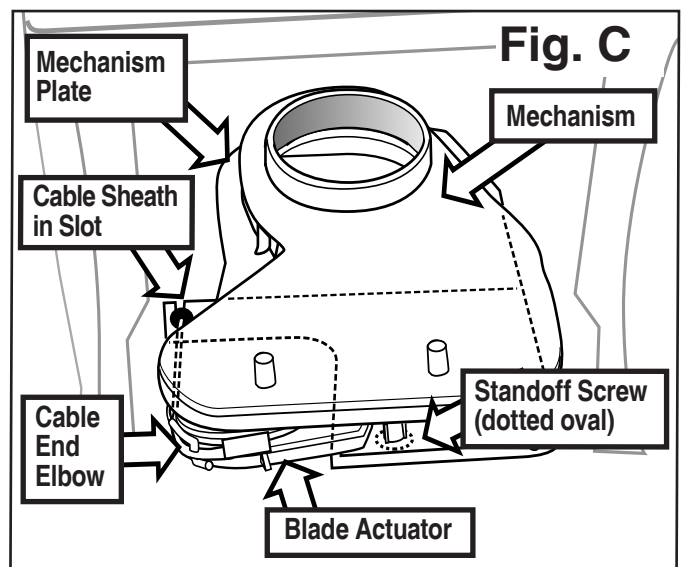
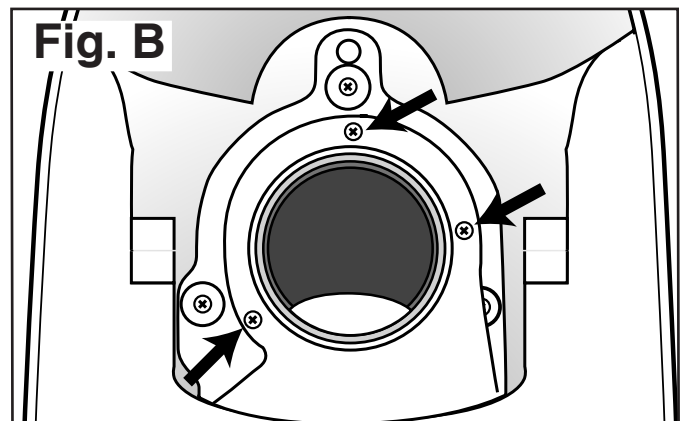
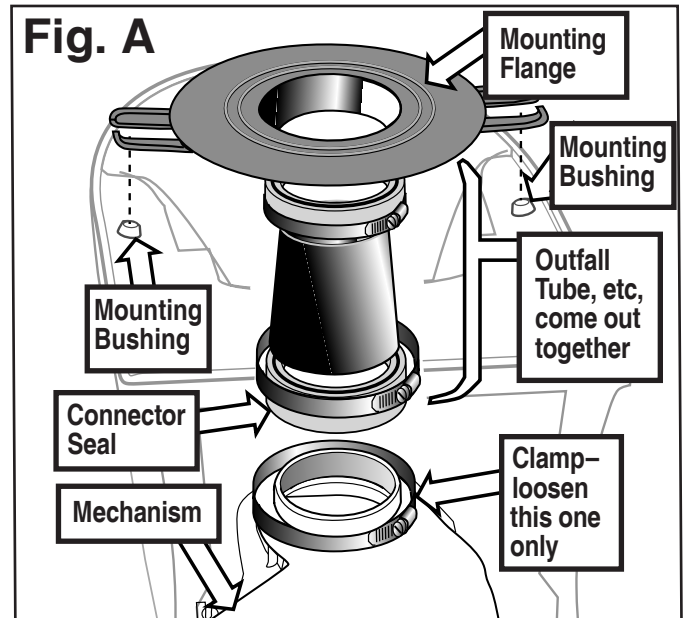

groove and is flush to Blade (Fig. D).

2. Slide Mechanism back into place and seat.
3. Replace 3 Screws that attach Mechanism to Plate (Fig. B).
4. Replace Mechanism standoff Screw (Fig. C).
5. Snap Cable Sheath fitting back into left side Mechanism Plate slot (Fig. C).
6. Replace Mounting Flange, Mounting Bushings, Outfall Tube (high-profile only) and Connector Seal (Fig. A).

### **To Reinstall Toilet To Floor**

1. Install new Closet Flange Seal to Toilet Mounting Flange, lip side outward. Friction holds it in place.
2. Keeping Mechanism Blade open to assure holes line up, position Toilet over Closet Flange.
3. Reconnect Water Supply Line.
4. Secure Toilet to floor with Lag Screws. Tighten.
5. Turn on RV's water supply. Flush test and fill bowl. Wait long enough to make sure new Blade Seal holds water.
6. Install Bolt Caps.

### **Tools Needed**

- Adjustable wrench
- 7/16" wrench
- Flat-blade screwdriver
- Pliers

