



120 VOLTS AC and 12/24 VOLTS DC
DUAL VOLTAGE REFRIGERATORS

INSTALLATION AND OWNER'S MANUAL

DE105, **3.3** Cubic foot, AC/DC refrigerator

Service Information

If service or parts are required, contact the nearest Norcold Service Center. To find an authorized Norcold Service Center near you, please telephone the Norcold Customer Support Dept. at 800-543-1219 (option-1) or visit our web site at www.norcold.com.

Special Requirements for Marine Installations:

These refrigerators are internally wired so that the AC and DC circuits are isolated from each other. If the positive (+12/24 volts) input is grounded (by cuts in the wire insulation, incorrectly insulated components, etc.) a voltage potential can be caused throughout the boat, which causes corrosion to form on any metal parts that are exposed to water.

This condition can be avoided by wiring the boat so that the AC and DC grounds are common and so the wiring is protected per NNMA CERTIFICATION HANDBOOK (1987). Inspect all wiring to make sure that the insulation is not damaged and use plastic wire clamps.

One reference for more information on corrosion is:

BOAT AND YACHT CORROSION CONTROL by
Yacht Corrosion Consultants, Inc.
2368 Eastman Ave. #6
Ventura, CA 93003

Norcold Customer Support Dept.
Telephone : 800-543-1219
Fax : 937-497-3183
Web Site: www.norcold.com

10/07/2017
Norcold Part No.639787A
#5490 176 5300

Table of contents

Norcold AC/DC Models - Two Year Limited Warranty.....	3
Norcold AC/DC Models - Warranty Information.....	3
Norcold AC/DC Models - Warranty Questions	4
Safety Awareness.....	5
Safety Instructions.....	5
About Your Refrigerator.....	6-7
Usage.....	6
Storage volume.....	6
Food compartment.....	6
Freezer compartment.....	6
Door latch for travel.....	6
Model No. and Serial No.	6
Operation.....	6
Protection System.....	7
DC Operation Guidelines.....	7
Refrigerator Care Checklist.....	7-9
Defrosting.....	8
Cleaning.....	8
Door Sealing.....	9
Troubleshooting.....	9-10
If refrigerator does not cool correctly in either AC or DC mode.....	9
Over heating shut-off device operation.....	10
Low voltage protection system.....	10
Over current protection system.....	10
Refrigerator Maintenance Checklist.....	10
Replacement Parts.....	11
Disposal.....	12
Installation.....	12
Assemble the Enclosure.....	13
Ventilation Requirements.....	13
Installation Options.....	14-15
Install the decorative door panel.....	14
Reverse the door swing.....	15
Connect the Electrical Components.....	16
Electrical current necessary.....	16
Connect the 120 / 220 volts AC supply.....	16
Connect the 12 / 24 volts DC supply.....	16
Install the refrigerator.....	18

NORCOLD AC/DC Models - Two Year Limited Warranty

Norcold, Inc. warrants for a period of two (2) years from the date of purchase that Norcold, Inc. will repair or replace its AC/DC refrigerators.

Limitations of Warranty

1. This warranty is the only warranty for Norcold AC/DC refrigerators. This warranty does not cover glassware, electric light bulbs or replaceable fuses.
2. This warranty does not apply to refrigerators or component parts that have been subjected to misuse, improper installation, abnormal service, transit damage, recharging of cooling unit system, accident, fire, improper repair, tampering or abuse.
3. The duration of any implied warranty is limited to two (2) years.
4. Some states do not allow limitations on how long an implied warranty lasts, so the above limitation may not apply to you.

Limitations of Remedy

1. The responsibility of Norcold under this or any warranty is limited to the repair or replacement (at Norcold's option) of any defective refrigerator or component part.
2. **In no event and under no circumstances shall Norcold be responsible for any other charge whatsoever, including but not limited to charges or claims for labor, lost business, lost time, lost profits, loss of use, or any kind of incidental or consequential damages, however denominated or described.**
3. Some states do not allow for the exclusion or limitation of incidental or consequential damages, so the above exclusion may not apply to you.

To obtain warranty service, contact Norcold Customer Service at (800) 543-1219 or visit our website at www.norcold.com.

Legal Rights

This warranty gives you specific legal rights, and you may have other legal rights which vary from state to state.

Norcold AC/DC Models - Warranty Information

Your refrigerator is made to provide the ultimate in cooling satisfaction and will serve you reliably in the years to come. Norcold refrigerator offer a standard limited two-year warranty.

To activate your two-year limited warranty, complete and mail the warranty registration supplied

Help us to help you.

Write the model number and serial number below for future reference. These numbers are on the serial plate in the refrigerator. The serial plate is located in the fresh food compartment on the top right hand side. Use these numbers when receiving service or in any correspondence concerning your refrigerator.

Model number _____ Serial number _____

If a problem occurs with your refrigerator, contact any of the service centers throughout the United States and Canada. To find an authorized Norcold Service Center near you, please telephone the Norcold Customer Support Dept at 800-543-1219 (option-1) or visit our web site at www.norcold.com.

Norcold is committed to providing products that are in harmony with the environment. Your Norcold refrigerator meets all environmental safety standards

Norcold AC/DC Models - Warranty Questions

This warranty is the only warranty for your Norcold refrigerator. There are no other express warranties. The only uses for this product are described in this manual. Part or model specifications are subject to change without notice.

What does this warranty cover?

This warranty covers labor and freight (ground service only) and costs incurred in removing and reinstalling the refrigerator when necessary to replace a defective part and any parts replaced under warranty (including cooling units).

What is not covered by this warranty?

- Travel expenses for bringing the refrigerator to an authorized Norcold Service Center for warranty coverage.
- Additional costs caused by the inability to bring the refrigerator to an authorized Norcold Service Center.
- Defects which are caused by transit damage, misuse, neglect, or accident.
- Manufacturing defects found at the time of purchase, parts replaced under warranty, and associated labor, which the original consumer-purchaser does not communicate to Norcold within 30 days.
- Labor, performed without need for parts replacements, which the original consumer-purchaser does not communicate to Norcold within 30 days.
- Defects in glassware, electric light bulbs, or replacement fuses.
- Defects caused by improper installation, maintenance, or adjustment.
- Normal maintenance of this refrigerator as described in this manual.
- Defects caused by the improper use of parts or parts not manufactured or supplied by Norcold for repairs or replacements to the refrigerator.

Norcold will not be liable for any incidental or consequential loss or damage, due directly or indirectly to the use of this product. Some states do not allow the exclusion or limitation of incidental or consequential damages, so the above may not apply to you.

How long does this warranty last?

This warranty is effective for a period of two years from date of purchase.

What will Norcold do?

Norcold will provide free service and replacement of defective parts, at no charge, at all authorized Norcold Service Centers. Norcold has the option of replacing the defective parts or the entire refrigerator. If the refrigerator is replaced, Norcold is not responsible for replacing dealer installed options.

How do you get service?

Bring the refrigerator to any authorized Norcold Service Center and show proof that the defective item is within warranty coverage. If you are unable to bring the refrigerator to an authorized Norcold Service Center:

- Send a written notice of the defect to Norcold.
- Norcold will promptly advise you how to obtain warranty service.

What rights do you have?

This warranty gives you specific legal rights. You may also have other rights which vary from state to state.

Safety Awareness

Read this manual carefully and understand the contents before you install the refrigerator.

Be aware of possible safety hazards when you see the safety alert symbol on the refrigerator and in this manual. A signal word follows the safety alert symbol and identifies the danger of the hazard. Carefully read the descriptions of these signal words to fully know their meanings. They are for your safety.



This signal word means a hazard, which if ignored, can cause serious personal injury, death, or much property damage.



This signal word means a hazard, which if ignored, can cause small personal injury or much property damage.

Safety Instructions



- For installations which need an electric outlet that is energized by an external power source, the refrigerator must be electrically grounded as written in local codes or the National Electrical code, NFPA 70.
- Incorrect installation, adjustment, alteration, or maintenance of this refrigerator can cause personal injury, property damage, or both.
- Obey the instructions in the "Ventilation Requirements" section of this manual.
- Do not bypass or change the refrigerator's electrical components or features.
- Protect all wiring from physical damage, vibration, and excessive heat.
- Do not spray liquids near electrical outlets, connections, or the refrigerator components. Many liquids are electrically conductive and can cause a shock hazard, electrical shorts, and in some cases fire.
- This appliance is intended to be used in household and similar applications such as recreational vehicles, boats, and semi trucks.
- To avoid a hazard due to instability of the appliance, it must be fixed in accordance with the instructions.
- A means for disconnection from the supply mains must be incorporated in the fixed wiring in accordance with the wiring rules.
- It is necessary to allow disconnection of the appliance from the supply after installation. This disconnection may be achieved by having the plug accessible or by incorporating a switch in the fixed wiring in accordance with the wiring rules.
- The storage of flammable materials behind or around the refrigerator creates a fire hazard. Do not use the area behind the refrigerator to store anything, especially flammable materials (gasoline, cleaning supplies, etc.)
- Do not store any explosive substance, such as aerosol cans with flammable propellant, in this refrigerator.
- Do not remove the round ground prong from the refrigerator AC power cord. Do not use a two prong adapter or extension cord on the AC power cord.
- A circuit overload can result in an electrical fire if the wires and for fuses are not the correct size. Use only the wire and fuse sizes as written in the "Installation Manual".
- Incorrect installation, adjustment, change to, or maintenance of this refrigerator can cause personal injury, property damage, or both. Have service and maintenance work done by your dealer or by an authorized Norcold Service Center.
- This refrigerator has more than one power supply. Disconnect both the AC and DC power sources before doing any maintenance work on the refrigerator All service work on this refrigerator must be done by a qualified service technician.
- Do not bypass or change the refrigerator's electrical components or features.
- When you discard an appliance, remove all doors to prevent accidental entrapment and suffocation.



- The rear of the refrigerator has sharp edges and corners. To prevent cuts or abrasions when working on the refrigerator, be careful and wear cut resistant gloves.
- This appliance is not intended for use by persons (including children) with reduced physical, sensory or mental capabilities, or lack of experience or knowledge, unless they have been given supervision or instruction concerning use of the appliance by a person responsible for their safety. Children should be supervised to ensure that they do not play with the appliance.

About Your Refrigerator

Usage:

This refrigerator is made for use within a recreational vehicle, marine, or truck application. Do not expose the refrigerator to rain.

Storage Volume:

This refrigerator is made to store fresh and frozen foods and for making ice.

DE105 3.3 Cubic feet

Food compartment:

Start up the refrigerator and let it cool for eight hours before loading with food. If the refrigerator does not start to cool down after about two hours, contact your dealer or an authorized Norcold Service Center.

For the best cooling performance:

- Let air move freely inside the entire food compartment
- Do not cover the shelves with plastic, paper etc.

To decrease the amount of ice that collects on the freezer plates

- Cover all liquids and moist foods.
- Let all hot foods cool before putting them in the refrigerator.
- Do not open the door any longer than necessary.

Freezer compartment:

The freezer compartment is made to keep pre-frozen food frozen and not to quick freeze food. Keep pre-frozen foods in the freezer compartment.

NOTICE

NOTE: When making ice, put the ice cube tray directly on the freezer surface. Do not put other items on the ice cube tray while the water is freezing. The water freezes more rapidly if the power switch / thermostat is at the coldest temperature setting.

Door latch for travel:

During travel, the door latch prevents the door from opening. There are no chains, slides, or any devices that you must engage

Model No. and Serial No.

The model and serial number are on a label which is inside the refrigerator on the left side.

Operation

This refrigerator is made for refrigerating purposes and operates on 120VAC or 12/24 VDC power when installed as written in this manual. The correct supply voltage(s) is located on the serial plate.

AC is the primary power source. When an AC source is not available, a built-in relay automatically switches the refrigerator operation to the DC power source. If the refrigerator is operating on the DC power source and AC power becomes available, the relay switches the refrigerator operation to the AC power source.



Never store combustible materials near the refrigerator. Storing combustible materials near the refrigerator creates a safety hazard and also decreases the ventilation of the cooling system which decreases the refrigerator performance. Do not store explosive substances such as aerosol cans with flammable propellant in this appliance.

NOTICE

Check if the voltage noted on the type plate on the refrigerator matches the one applied by an external power source.

The refrigerator temperature is controlled by a thermostat, located in the refrigerator. A light, located on the panel comes on when the refrigerator is "ON". Number "1" is the warmest and number "5" is the coldest thermostat position. For efficient operation, change the thermostat according to the types of food stored and the ambient temperature.

If you are not going to use the refrigerator for an extended period of time, put the thermostat to the "OFF" position (full counterclockwise position).

Protection System

Your refrigerator has an over current protection system in the electronic circuit to prevent damage to the inverter which may occur due to a reverse polarity connection.

If the refrigerator does not operate and the interior light does not come on, check the fuse, which is located on the side of the inverter case, and the polarity of the DC power supply. If the refrigerator still does not operate, another problem can exist in the inverter. Have an authorized Norcold Service Center check the refrigerator.



Do not operate the refrigerator when the ambient temperature is higher than 110°F. Operation when the ambient temperature is higher than 110° F. can cause poor cooling performance and permanent damage to the compressor.

DC Operation Guidelines



Do not operate the refrigerator on battery power only. Operation of the refrigerator directly from the battery will rapidly discharge the battery. Correctly supply DC power to the refrigerator.

The refrigerator gets DC power from the vehicle battery system. The battery system also supplies power to any other DC appliances or accessories of the vehicle.

Refrigerator Care Checklist

Your refrigerator will give you years of trouble free service if you do these simple checks every three to six months:

- Keep the food compartment and the freezer clean. See "Cleaning"
- Defrost the refrigerator as necessary See "Defrosting".
- Make sure the door seals correctly. See "Door Sealing".
- Be aware of any cooling changes that are not because of weather, loading or thermostat changes. If changes occur, contact your dealer or authorized Norcold Service Center.
- Make sure the air flow in the lower intake vent, through the refrigerator condenser and coils and out the upper exhaust vent is not blocked or decreased.

Defrosting:

The freeze plates of the refrigerator operate at below freezing temperature and will naturally form frost from humidity, which is always present in the air. The humidity inside the refrigerator increases:

- with higher outside temperature and humidity.
- with the storage of non-sealed fresh foods or warm foods.
- with the amount of time that the door(s) are open.
- with any air leakage into the refrigerator.

It is normal for frost to collect inside the refrigerator. Excess frost decreases the cooling performance of the refrigerator. Defrost the Refrigerator as necessary:

- Remove all food from the refrigerator.
- Turn the refrigerator OFF.
- Put dry towels (etc.) inside the refrigerator to help remove the excess water.



High temperatures can cause the inside surfaces of the refrigerator to warp or melt. Do not use pans of HOT water, a hair dryer, or any other high temperature devices to defrost the refrigerator. Do not use any hard or sharp object to remove frost. Damage to interior of refrigerator can occur.

- To increase the speed of defrosting, put pans of WARM water in the refrigerator.
- Remove the wet towels (etc.) and dry the interior.
- Start up the refrigerator.
- Allow the refrigerator to cool down.
- Return all food to the refrigerator.

Cleaning:

A good time to clean the refrigerator is just after you defrost it.

Clean the inside of the refrigerator as often as necessary to avoid food odors:

- Remove all food from the refrigerator.



Do not use abrasive cleaners, chemicals, or scouring pads because they can damage the interior of the refrigerator.

- Wash the interior with a mild cleaner or a solution of liquid dish detergent and warm water.
- Rinse with a solution of baking soda and clean water.
- Dry with a clean cloth.
- Put all food back into the refrigerator.

To remove and clean the drip tray:

- Make sure that the drip tray is empty of water.
- Pull the drain tube plug out from the inside of the drip tray and out of the drain hose.

- Pull the drip tray down to remove from the slots in the refrigerator cabinet.
- Clean the drip tray.
- Put the drain tube plug down into the drip tray and push the drip tray back into the original position.
- Push the drain hose back onto the drain tube plug.

Door sealing:

If the door does not seal correctly, excess frost will collect inside the refrigerator. Make sure the door seals correctly.

- Close the door on a piece of paper that is about the size of a dollar bill (See Art00980).
- Gently pull the paper.
- You should feel a slight drag between the gasket and the cabinet.
- Do this on all four sides of the door.
- If you do not feel a slight drag on the paper, the door is not sealing correctly.
- Have your dealer Or an authorized Norcold Service Center correct the seal of the door.

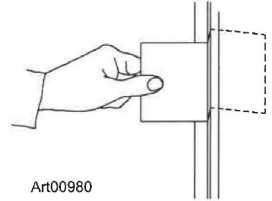

Trouble shooting

If the refrigerator does not cool correctly in either AC or DC mode:

- Make sure the power switch / thermostat is not in the OFF position.
- Make sure the power switch / thermostat is at the temperature setting that you wish
- Make sure that the power source(s) to the refrigerator is serviceable.
- Make sure that the fuse or circuit breaker is intact (See “Over current protection system”)
- Make sure that the refrigerator is correctly installed and that the built in vents are not blocked.
- Make sure that the ambient temperature is not unusually high(more than 110° F/43° C.)
- Make sure that the door is closed.

If the weather is hot, make sure that the door is sealing correctly.

- Make sure that the air circulation inside the refrigerator is not decreased by foods or by shelves that are covered with plastic, paper, etc.
- Make sure that hot foods were not placed in the fresh food compartment of the refrigerator.
- Make sure that the freezer is defrosted

After you make these checks, if the refrigerator does not operate, contact your dealer or an authorized Norcold Service Center.

Over heating shut-off device operation:

Operating the refrigerator in high ambient temperatures can over heat the cooling unit and cause premature failure of the compressor (See the label inside the refrigerator).

To protect the cooling unit from over heating, the refrigerator will automatically shut-off when the temperature of the power module is higher than 212° F (100° C). The refrigerator will not restart until the temperature of the power module is lower than 176° F (80° C).

Low voltage protection system:

In order to prevent completely draining the battery, the refrigerator will automatically shut-off when the DC supply voltage becomes too low. The refrigerator will not restart until the DC supply voltages increases. These shut-off and restart voltage levels are:

12VDC Operation	24 VDC Operation
Shut-off 10.4VDC	Shut-off 22.7VDC
Restart 11.6VDC	Restart 24.0VDC

If the DC supply voltage is between 17 and 22.7VDC, the refrigerator will not operate.

Over current protection system:

Your refrigerator has an over current protection system in the electronic circuit to prevent damage to the inverter which may occur due to a reverse polarity connection.

If the refrigerator does not operate and the green power light does not come on, check the fuse, which is located in-line with the DC connector, and the polarity of the DC power supply. If the refrigerator still does not operate, another problem can exist in the power module. Have an authorized Norcold Service Center check the refrigerator.

Refrigerator Maintenance Checklist

Read and understand the following maintenance sections of this manual.

NOTICE Norcold is not responsible for installation, adjustment, alteration, service, or maintenance performed by anyone other than an authorized Norcold Service Center.

Have an authorized Norcold Service Center do these annual safety and maintenance checks:

- Make sure the AC and DC voltages are correct (See the “Electrical current necessary” section).
- The wire connections must be clean, tight and free of corrosion. If any of these items are not correct:
- A voltage drop to the refrigerator will occur.
- The voltage drop will decrease the cooling performance of the refrigerator.



Disconnect the positive(+) DC power supply wire from the battery before you do a “fast charge” of the battery. Failure to disconnect the positive(+) power supply wire from the battery during a “fast charge” can cause damage to the refrigerator or other 12 volt DC appliances.

Battery Maintenance

Over cooling drains your battery

When the ambient temperature is between 70° and 90° F, keep the thermostat at the “3” position to avoid an excessive drain of the battery. When making ice, or storing frozen foods, turn the thermostat to the coldest setting “5”.

Maintain the battery

If the charge of your battery is not sufficient, the cooling performance of your refrigerator decreases.



Only use a “quick charger” on the battery if the thermostat is turned to “OFF”.

Check the Battery charge Level

A fully charged battery will have a specific gravity reading of between 1.260 and 1.280. The battery voltage is best indicated when the refrigerator is "ON" and the battery charging system is "OFF". Charge the battery when the specific gravity reading is less than 1.200.

For your reference

The wiring diagram shown below is recommended for dual battery hookup.

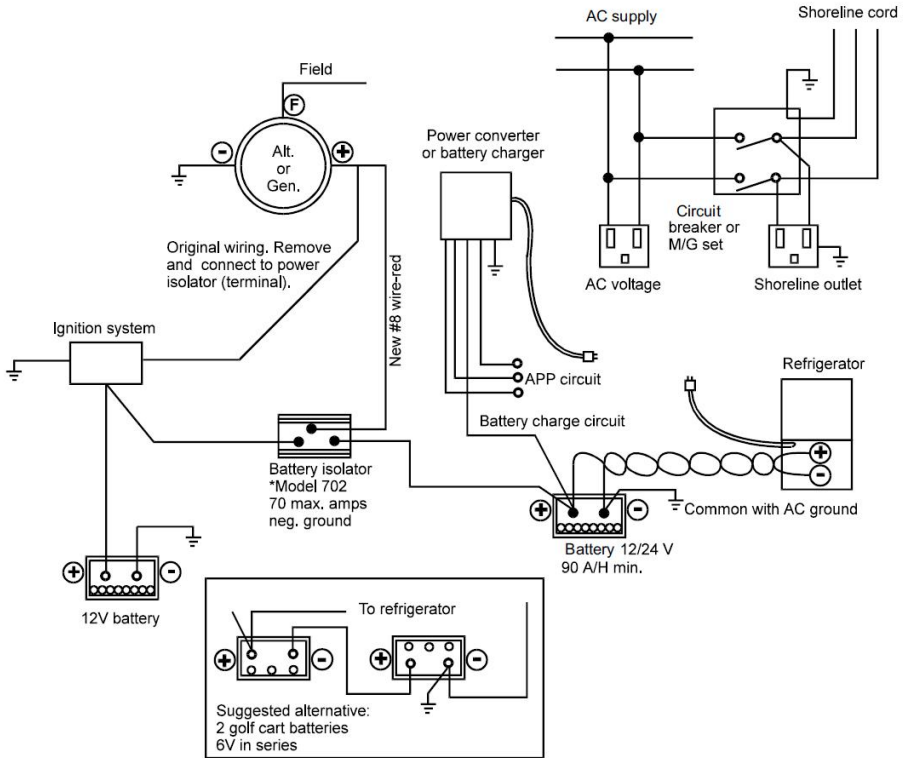

Replacement Parts

You may purchase replacement parts through your dealer or an authorized Norcold Service Center.



If the supply cord is damaged, it must be replaced by the manufacturer, its service agent or similarly qualified persons in order to avoid a hazard.

Disposal



To prevent the risk of child entrapment, before you discard your old refrigerator:

- Remove the doors from the refrigerator.
- Let the shelves stay in position so that a child may not easily climb inside the refrigerator.
- This refrigerator is marked with this symbol. It means that used electrical and electronic refrigerators should not be mixed with general household waste.



If you wish to dispose this refrigerator, contact your local authorities and ask for the correct method of disposal, or specialist dealer for details about how to do this in accordance with the applicable disposal regulations.

- Cyclopentane is used in the insulation. The gases in the insulation material require a special disposal procedure. Please contact your local authorities in regard to the environmentally safe disposal of the refrigerator.

Installation

The refrigerator must be located and secured on a solid surface in the vehicle or watercraft.

Before installing the refrigerator into the opening, make sure the DC supply is properly connected.

Measure the opening to determine if you have proper clearance for installation. Additional insulation space around the refrigerator is not necessary.

Be sure the refrigerator is not in direct sunlight or near a gas stove, a heater, or other heat-generating appliances. Avoid installing your refrigerator close to warm water lines or warm air ducts.

Your refrigerator was thoroughly cleaned before shipment from the factory. It is advisable, however, to clean the interior once more before using. Wipe the interior with a cloth and warm water. Then wipe with a dry cloth.

Assemble the Enclosure

Make sure that the enclosure is the correct size:

- For DE 105 models - 30 inches high x 20.75 inches wide x 20.13 inches deep.

Make sure the floor is solid and level:

- The floor must be metal or a wood panel and extend the full width and depth of the enclosure, plus must extend 1 $\frac{3}{8}$ inches beyond the front of the enclosure.
- The floor must be able to support the weight of refrigerator and its contents.

Make sure there are no adjacent heat sources such as a furnace vent, etc.

Ventilation Requirements

This refrigerator is made for a built-in installation. Correct ventilation is necessary for the correct operation of the refrigerator and to increase the life of the refrigerator cooling system.

Ventilation allows the natural air flow that is necessary for good refrigeration. Cooler air comes in through a lower intake vent, goes around the refrigerator coils where it removes the excess heat from the refrigerator components, and goes out through an upper exhaust vent. If this air flow is blocked or decreased, the refrigerator will not cool correctly. Do not install the vents into completely enclosed areas such as closets or cabinets.



The refrigerator has built in vents at the top and at the bottom. Make sure that the flow of air through these vents is not blocked in any way. Blockage of air through these vents can cause:

- shortened life of the refrigerator cooling unit.
- poor cooling performance of the refrigerator.
- continuous operation of the refrigerator.
- fast battery discharge.
- void of the refrigerator warranty.

Do not remove the bottom rails from the refrigerator cabinet. The rails supply space under the refrigerator that is necessary for correct ventilation. lerated battery discharge and a void warranty will result.

If you do not make sure that the ventilation is correct, a shortened refrigerator life expectancy, poor refrigeration, continuous operation, accelerated battery discharge and a void warranty will result.

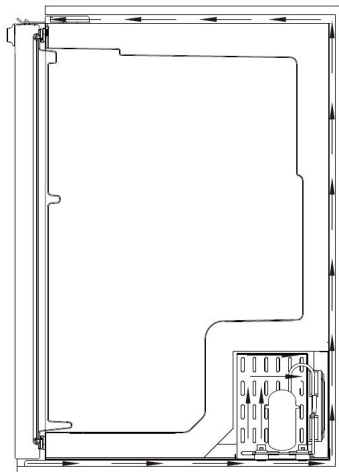

Installation Options

Install a decorative door panel

NOTICE

The decorative door panel must be 2.0 mm or (0.08 inches) less in thickness.

1. Remove the door from the refrigerator by removing the three screws that attach the door hinge to the bottom of the refrigerator.
2. Remove the panel retainer by removing the four (4) screws that attach the panel retainer.
3. Gently pull the door panel out of the Door Slot.
4. Push a new door panel into the door Slot.



Do not overtighten the screws and bolts.

5. Put the panel retainer in the original location and attach with four (4) screws.
6. Put the door in the original location and tighten the three (3) screws.

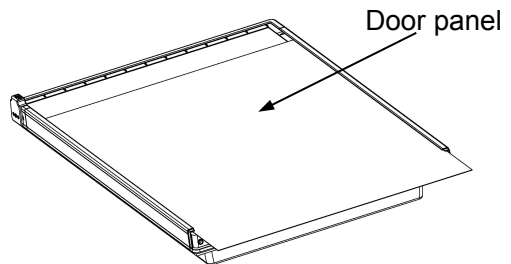
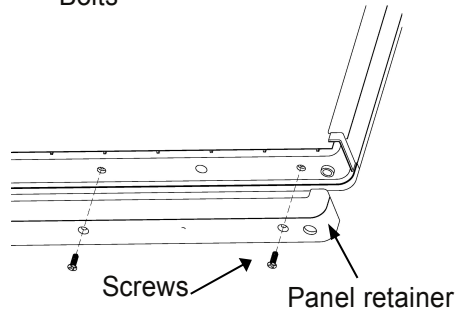
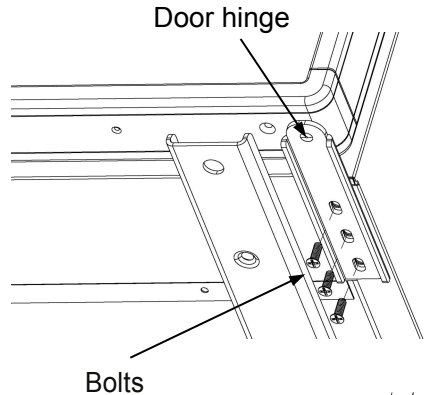

Reverse the door swing:

- 1.Remove the door from the refrigerator by removing the three (3) screws that attach the door hinge to the bottom of the refrigerator.
- 2.Open the door and pull it off of the top hinge pin.
- 3.Remove the three (3)screws that attach the grill.
- 4.Remove the three (3) screws that attach the upper hinge.
- 5.Remove the bolt that attaches the door latch plate to the top of the refrigerator.
- 6.Remove the upper hinge and the door latch plate from the refrigerator.
- 7.Attach the upper hinge and the door latch plate to the opposite sides of the refrigerator.
- 8.Move the latch to the opposite side of the door.
 - Remove the screw that attaches the latch handle and the latch pin.
 - Remove the latch handle pin and the coil spring from the door.
 - Move the set screw to opposite side of the latch pin.
 - Assemble the coil spring and the latch pin into the opposite side of the door.
 - Attach the handle to the latch pin.
 - Make sure that the angled end of the latch pin is up.
- 9.Put the door onto the refrigerator and make sure that the gasket seals correctly.
- 10.Install and tighten the three (3) screws that attach the door hinge to the bottom of the refrigerator.

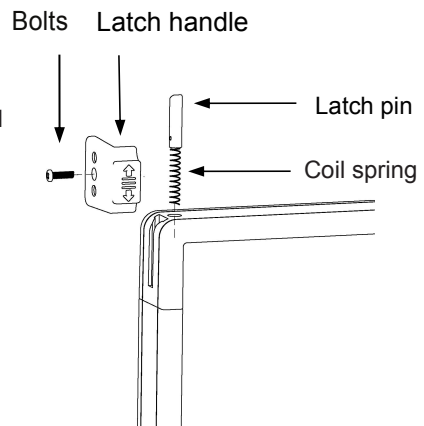
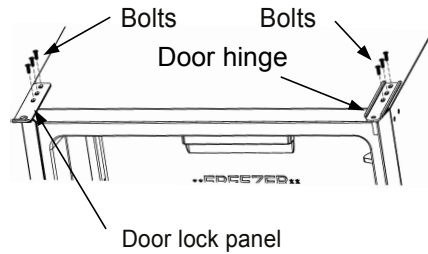

Connect the Electrical components

Electrical current necessary:

AC Operation	DE105	- 120 volts AC voltage (108 volts min. -132 volts max.) - 59 Hertz min. -61 Hertz max
DC Operation	DE105	- 12 volts DC voltage (10.9 volts min. -17volts max.) - 24 volts DC voltage (22.7 volts min. -31.5volts max.)

This refrigerator operates on both AC and DC electronic sources. Operation out of these limits may damage the refrigerator's electrical circuit parts and will void the warranty.

Make no changes to any of the electrical wiring supplied with the refrigerator. Any changes that you would make to the electrical wiring will void the warranty.

Connect the 120 volts AC supply:



Connect the AC power cord only to a grounded three-prong receptacle. Do not remove the ground prong from the power cords. Do not use a two-prong adapter or an extension cord. Operation of the refrigerator without correct ground can cause dangerous electrical shock or death if you are touching the metal parts of the refrigerator.

Put the AC power cord into a grounded three-prong receptacle.

- Make power sure source the is AC used power to the receptacle goes through a fuse or a circuit breaker which will protect the vehicle when an outside.
- If the AC power to the receptacle is supplied by an on-board generator ,make sure that both the voltage and frequency are within the specified limits(See the“Electrical current necessary”section).

Connect the 12/24 volts DC supply

To reduce the risk of electrical interference from other DC appliances and induction from voltage spikes:

- The refrigerator must have an independent 12/24 volt DC supply.
- Route the DC power supply wires including the fuses directly from the battery to the refrigerator.
- Twist the DC power supply wires from the battery to the refrigerator.



Do not use a converter or a battery charge to supply the DC power to the refrigerator. These devices do not supply filtered DC power. When using a converter or a battery charger, make sure a battery is in-line between them and the refrigerator.

As the distance from the vehicle battery to the refrigerator increases, the correct AWG wire size also increases. If the wire size is too small for the distance, a voltage drop occurs. The voltage drop decreases the cooling performance of the refrigerator.

1. Find the minimum wire size to use:



Use only the recommended wire size.

- Measure the distance from the vehicle battery to the refrigerator:
- If the distance is 0 - 12 feet, use #12 AWG min. wire size.
- If the distance is 12-20 feet, use #10AWG min. wire size.
- If the distance is over 20 feet, use #8AWG min. wire size.

2. To protect the DC power supply wiring, install a 15 amp fuse or circuit breaker in the positive(+) DC power supply wire as close to the battery as possible.

- There is a 15 amp fuse in the DC circuit at the refrigerator power supply leads.

3. Connect the DC power supply wires .

NOTICE *If the DC power supply leads are attached incorrectly, the refrigerator will not operate.*

- Connect the positive (+) DC power supply lead to the red wire of the refrigerator.

- Connect the negative (-) DC power supply lead to the black wire of the refrigerator.

- Make sure that:

- Each DC power supply lead is attached to the correct polarity wire of the refrigerator power supply

- The chassis or the vehicle frame is not used as one of the conductors.

- The DC power supply wires including the fuses are routed directly from the battery to the refrigerator.

- The wire connections must be clean, tight and free of corrosion. If any of these items are not correct:

- A voltage drop to the refrigerator will occur.

- The voltage drop will decrease the cooling performance of the refrigerator.



Disconnect the positive(+) DC power supply wire from the battery before you do a “fast charge” of the battery. Failure to disconnect the positive (+) power supply wire from the battery during a “fast charge” can cause damage to the refrigerator or other DC appliances.

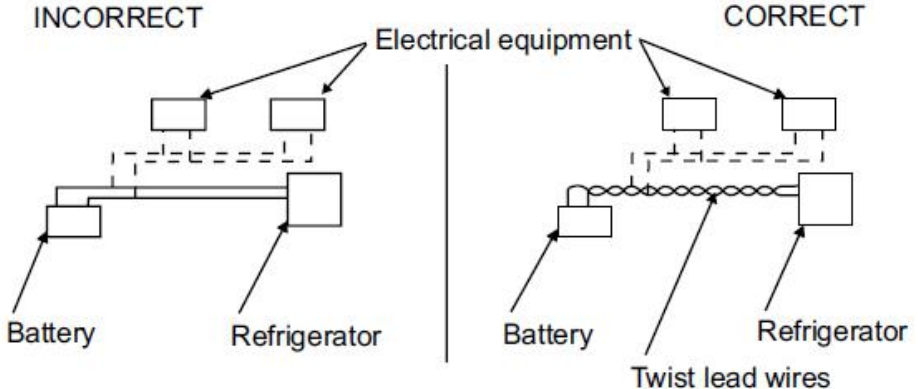

Install the refrigerator

1. Install the grill trim piece with 5 screws provided.

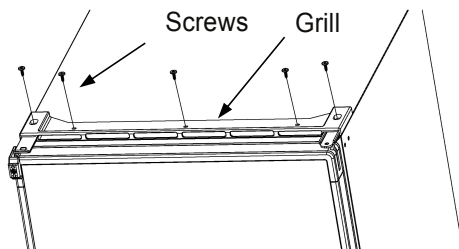

2. Fasten the refrigerator into enclosure.

- Push the refrigerator into the enclosure opening until the cabinet is flush with enclosure.
- Put the mounting screws through the mounting flange on both sides of the refrigerator in the front.

