

Cassette® C4 - Manual

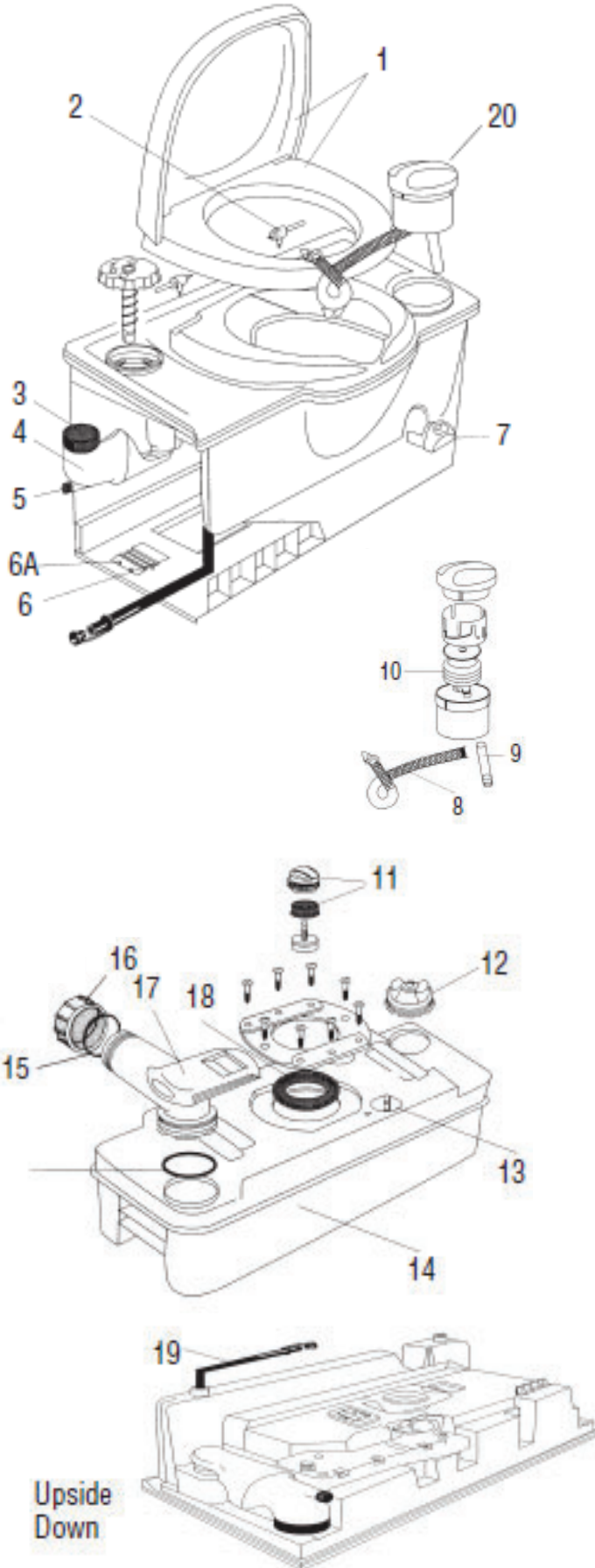

| Key No. | Part No. | Description |
|---------|----------|------------------------------------|
| 1 | 1619462 | Seat & Cover – White |
| | 33154 | <i>Superseded by 1619462</i> |
| 2 | N/A | Hinge Post/Pin (2) – White |
| 3 | N/A | Cap Water Fill Funnel |
| 4 | N/A | Water Fill Funnel Complete |
| 5 | 16385 | Drain Cap Water Fill Funnel |
| | 33337* | <i>Superseded by 16385</i> |
| 6 | 16169 | Spring (Retainer) |
| 6a | N/A | Clip and Clip Retainer – Yellow |
| 7 | N/A | Level Indicator – White |
| 8 | N/A | Flush Tube – White |
| 9 | 21066 | Inlet Tube |
| | 33356 | <i>Superseded by 21066</i> |
| 10 | 21065 | Bellows |
| | 33355 | <i>Superseded by 21065</i> |
| 11 | 2372274 | Automatic Vent |
| | 33210 | <i>Superseded by 2372274</i> |
| 12 | N/A | Vent Plug |
| 13 | N/A | Blade Opener |
| 14 | 20063874 | Holding Tank Complete (Right-Hand) |
| | 33205 | <i>Superseded by 20063874</i> |
| | 20063974 | Holding Tank Complete (Left-Hand) |
| 15 | 33206 | <i>Superseded by 20063974</i> |
| | 16195 | Cap and Spout Seals (2) |
| 16 | 33333 | <i>Superseded by 16195</i> |
| | 1638478 | Dump Cap |
| 17 | 33160 | <i>Superseded by 1638478</i> |
| | 2133374 | Sliding Cover |
| 18 | 33203 | <i>Superseded by 2133374</i> |
| | 16175 | Lip Seal (Pre-6/15/00) |
| | 33331 | <i>Superseded by 16175</i> |
| 19 | 23721 | Lip Seal (Post-6/15/00) |
| | 33361 | <i>Superseded by 23721</i> |
| | N/A | Drain Tube (Right-Hand) |
| 20 | N/A | Drain Tube (Left-Hand) |
| | N/A | Flasher |
| | N/A | Stop Retainer |
| | 2029162 | Flush Mechanism – White |

Not available

* Limited Availability