

Tools needed

- Flat-blade screwdriver
- Adjustable Wrench
- Pliers

Note:

- Read all instructions before beginning work.
- You may not need to replace all the Seals in this package.
- All replacements will require removing toilet from floor.
- Use gloves when handling parts that may have come in contact with waste.

To Remove Toilet From Floor

1. Turn off RV water supply per RV Owner's Manual.
2. Press both keypad buttons at the same time, twice, to open blade and drain bowl of water.
3. Pry off Bolt Caps with Flat-blade screwdriver. Use wrench to remove 1/2-inch Lag Screws.
4. Swivel Toilet to gain access to back.
5. Turn off RV's power supply to the Toilet.
6. Disconnect Water Supply Line with Adjustable Wrench (Fig. A).

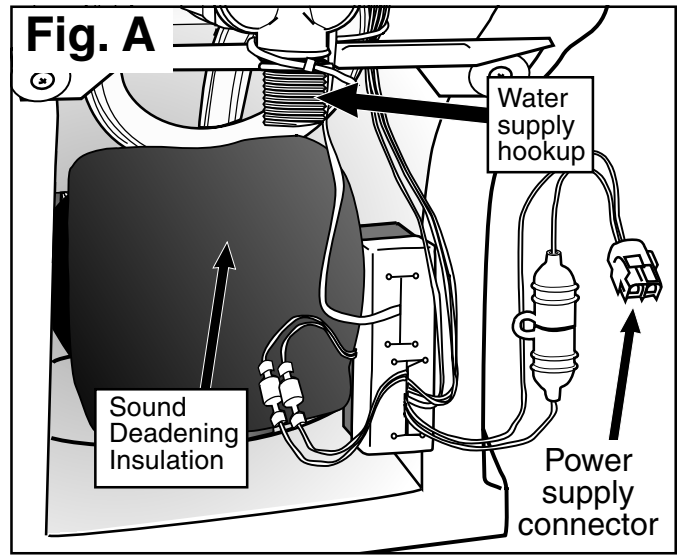

7. Disconnect Toilet's 12-volt power hookup to RV.
8. Place an old towel or soft cloth on work surface. Remove Toilet from floor and place upside down on work surface.
9. Remove old Closet Flange Seal (may be found in toilet or in floor at Closet Flange). Discard.
10. Cover Holding Tank opening to contain odor.

Replacement of Blade Seal, O Ring Seal and Hopper Seal

To Remove Parts

1. Tap out 2 Mounting Bushings (Fig. B).
2. Remove Mounting Flange and Flange Seal.
3. **High Profile models only:** Remove Extension Tube. It may be found connected to Mounting Flange or to the Mechanism. Remove Tube Seal.
4. If you need to replace the Blade Seal, remove 4 Mechanism Screws without Washers (MS, Fig. C). If not, remove the three screws shown with washers (no arrows).

5. Lift Mechanism Assembly off Seal. Pull out carefully through back of toilet, just far enough to gain access to the seal(s) to be replaced. (No need to disconnect/remove motor wiring, Overflow Tube or Sound Deadening Insulation from Mechanism.)

To Replace Blade Seal

1. Remove Blade Seal (may be attached to white Mechanism Plate). Discard. Fit new seal in its place.

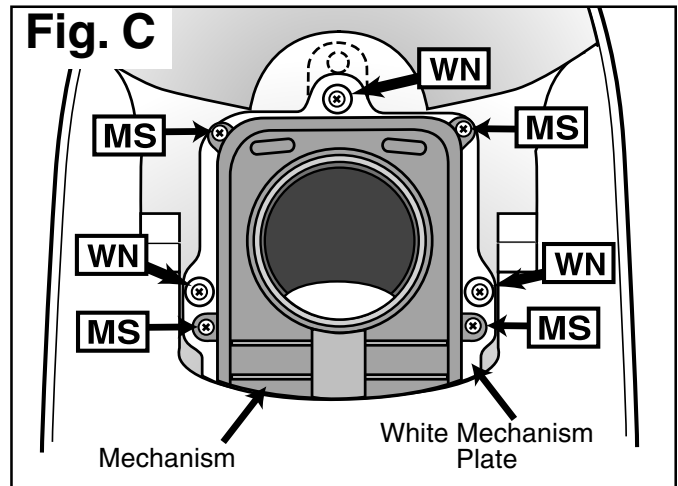
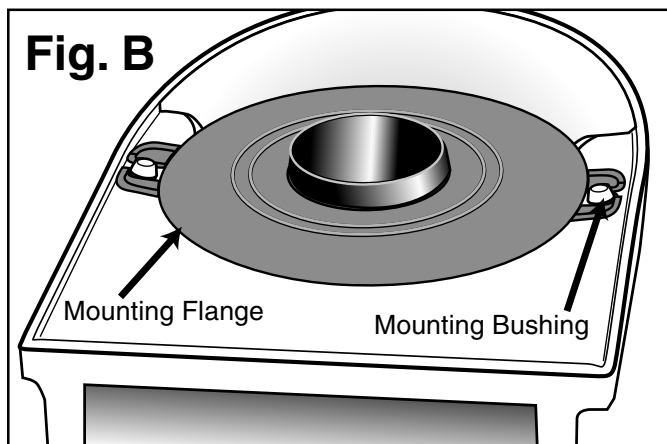

To Replace O-Ring Seal

If you do not need to replace this seal, skip down to **Re-install Mechanism** section below.

It is not necessary to remove Mechanism from toilet to install this seal. If you decide to remove it, disconnect the Overflow tube from top of Mechanism by twisting it off. Then disconnect the yellow and green Motor Lead, using pliers if necessary.

1. Remove the Sound Deadening Kit insulation (shown in Fig. A, preceding page) from Mechanism by unwrapping the Velcro™ strap.
2. Remove 6 End Cap Bolts from Mechanism. Remove End Cap (Fig. D).

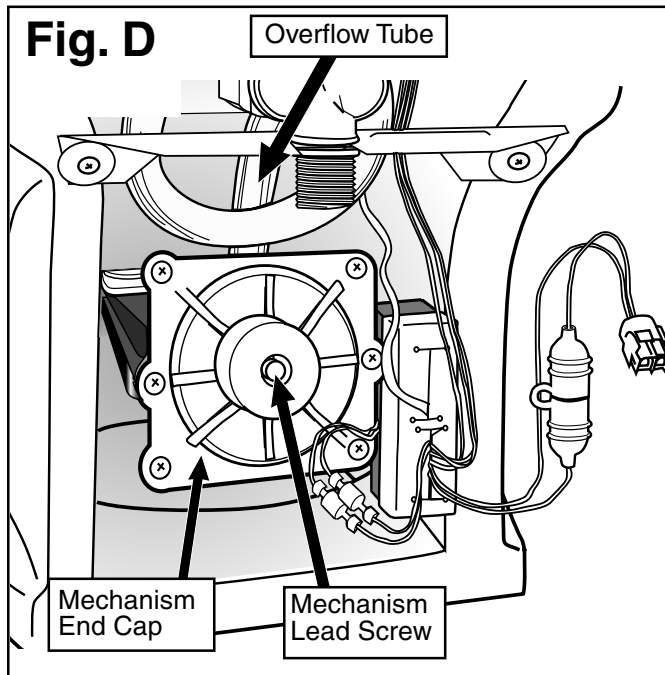

3. Grasp Gear/Clutch Assembly (Fig. E) and pull it out of the housing. This retracts the Valve Blade fully. The Lead Screw (Fig. F) is engaged in the Lead Screw Boss on the Valve Blade (not shown).
4. Turn Lead Screw counterclockwise until it releases from the Valve Blade. Withdraw the entire Gear/Clutch/Lead Screw Assembly.
5. On the back side of the Gear/Clutch subassembly (Fig. F) you will find a small black "O" Ring. Slide it off and replace it with the new one.

6. Slide the Gear/Clutch/Lead Screw Assembly back into the housing. Holding the Valve Blade, turn Lead Screw clockwise enough turns to fully engage the Lead Screw into the Valve Blade. Release the Valve Blade. **(Caution: wear gloves when handling Valve Blade or anything that may have come in contact with waste.)**
7. Re-engage the large gear with the small pinion gear (Fig. E) and slide the Gear/Clutch/Lead Screw Assembly fully into the housing.
8. Make sure curved washer is in place on the Lead Screw, concave side facing toilet. Reinstall End Cap and secure 6 Screws.
9. Replace the Sound Deadening Kit insulation onto Mechanism, securing it with the Velcro™ strap.

If you have removed Mechanism from toilet, do these steps now:

1. Reattach Overflow Tube to Mechanism.
2. Reattach 2 Wire Motor Leads, yellow to yellow and green to green.

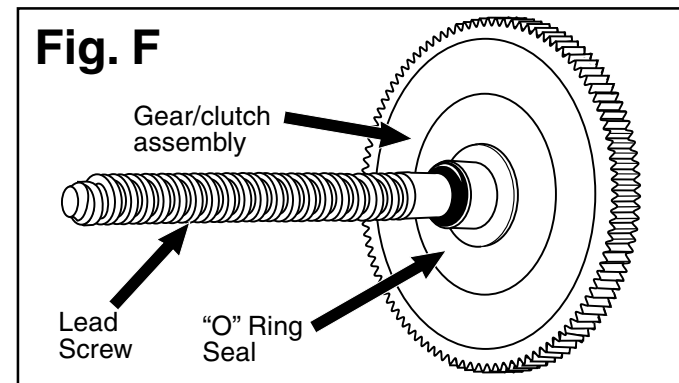
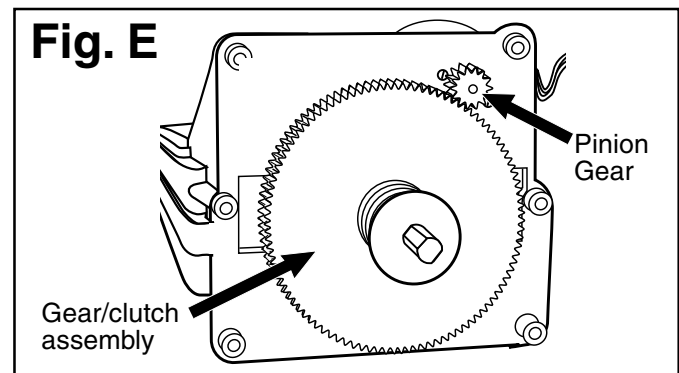

To Replace Hopper (Bowl Opening) Seal

If you do not need to replace this seal, skip down to **Re-install Mechanism** section below.

1. Unscrew 3 Well Nut Screws with Washers (shown without arrows in Fig. C, page 1) to free white Mechanism Plate.
2. Scrape off old Seal on china with sharp tool. Use mineral spirits to remove residue.
3. Apply a generous ring of provided Sealant around Bowl Drain opening (Fig. G, next page).
4. Apply Flat Foam Seal to sealant. Press down in place, cen-

ter the seal, and wipe away any excess sealant squeezed into opening.

To Replace Mechanism

1. Wet blade seal with clean water.
2. Fully seat new blade seal, lip up, onto Mechanism Plate (Fig. G).
3. To avoid damaging blade seal, make sure blade in new mechanism is fully closed. Turn mechanism lead screw counter-clockwise to close valve (Fig. D).
4. Connect 2 Motor Leads, yellow-yellow, green-green (Fig. A).

- Working from the back, position Mechanism in Toilet. *NOTE: on some low-profile units, it may be a tight squeeze.* Align mechanism over Mechanism Plate, press down and secure with four screws (MS, Fig. D).
- Turn toilet over to check centering. Loosen well-nuts to re-center if needed. **Do the permanent tightening down of the well-nut screws at this time by hand. Tighten in a diagonal pattern to get an even seal. Be careful not to over-tighten and cause deflection of the plate at the edges. Wipe off excess sealant when done.**
- Cut approximately 1" off Overflow Tube. Forming a full loop, reattach to Mechanism. Tuck in and away from lead screw.
- If you removed the Controller Assembly and/or the Switch Box, re-install now, using the adhesive foam pads provided. If you removed Metal Bracket, reinstall.
- High Profile:** To install Extension Tube (Refer to Fig. H):

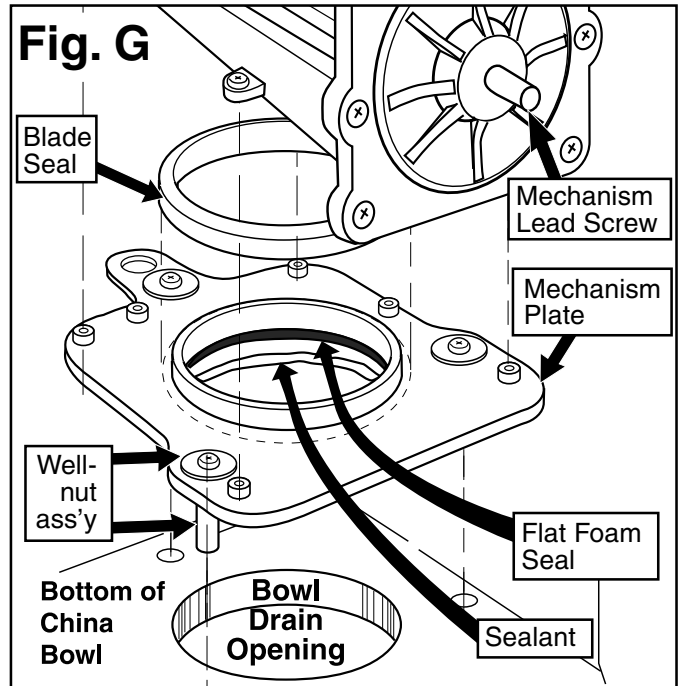
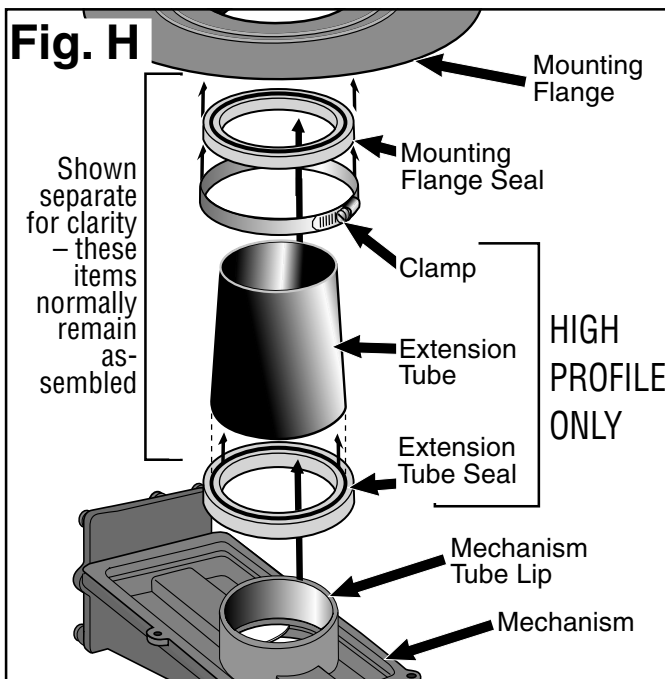

- Lubricate sealing surface of Extension Tube Seal with silicone grease.
- Install Extension Tube Seal on Extension Tube.
- Install Extension Tube and seal assembly on Mechanism. Make sure that seal is seated at least 1/2 inch below Mechanism tube lip.
- Ensure Hose Clamp on Mounting Flange Seal is tight.
- Lubricate Mounting Flange Seal sealing surface with Silicone Grease.
- Install Mounting Flange and Seal assembly on Extension Tube. Make sure there is at least a 1/2" overlap between the Extension Tube and Mounting Flange Seal.

Low Profile: Replace the Mounting Flange Seal onto the lip of the Mounting Flange. Install Mounting Flange to Mechanism. (No extension tube is used.)

- Replace 2 Mounting Bushings with flat surface out.

Replacing Flush Nozzle Seals

This does not require removing the Mechanism.

To Remove Old Parts

- Disconnect 2 upper Tubes from outside Nozzle Connectors (Fig. I).
- Cut Tie Strap securing Solenoid Valve to Metal Bracket (Fig. J).
- Being careful not to bend Metal Bracket, slide Solenoid Valve out of slot in Bracket. Swing entire Valve/Hose Assembly down and to right out of the way. Support it to avoid putting stress on the Wire Harness.
- Pop up Seat/Lid Bolt Covers (hinged from rear).

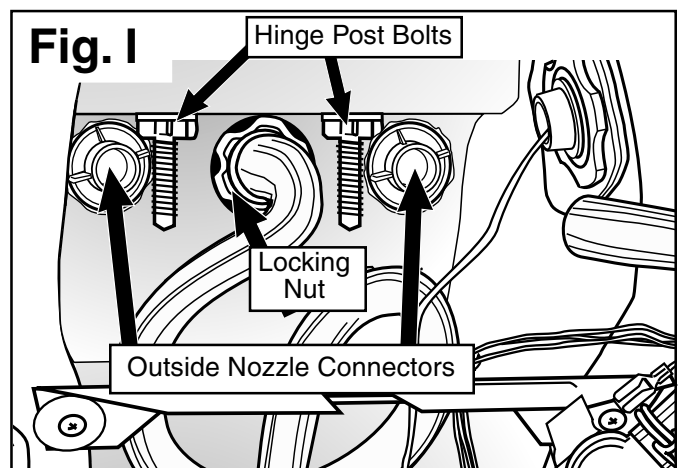

5. Holding Hinge Post Nuts from inside (Fig. J), turn screwdriver counterclockwise to unscrew Hinge Posts. Remove Nuts and Bolts (but not Seat/Lid).
6. Take note of Overflow Tube position for future reference. Pull Overflow Tube off center Nozzle Connector.
7. To remove 2 outside Nozzle Connectors (Fig. I), push them in, twist counterclockwise and pull back. (They may be caulked tight and difficult to remove. Use pliers if necessary.)
8. Remove Locking Nut from center Nozzle by turning counterclockwise until it releases. Save Locking Nut.
9. Scrape away 3 Seals and Sealant with a sharp-edged tool. Use mineral spirits to remove **all** residue.

To Replace Parts (Fig. K)

1. Push small Foam Seal over Flush Cover barb. Position new Flush Cover/Nozzle Assembly in bowl. (Be sure Foam Seal is stuffed completely/flush into opening.)
2. Apply Silicone Sealant to 3 Nozzle Seals. Adhere them to Toilet, one around each Nozzle.
3. Apply Silicone Sealant to another Nozzle Seal. Adhere it to the Seal already in place around center Nozzle.
4. Apply Silicone Sealant to flat side of Locking Nut. With flat side facing seals, place Locking Nut on center Nozzle. Holding Nozzle Assembly firmly in position from inside Toilet Bowl, Turn Locking Nut clockwise to lock. (**Note:** all 4 prongs must mate with locking ears to achieve proper lock.)
6. Apply Silicone Sealant to last 2 Nozzles. Adhere Nozzles to Connectors. Again Holding Nozzle Assembly firmly, push in hard and rotate clockwise (you will feel it lock).
7. Before Sealant sets, be sure to Nozzle to China Seal is uniform.
8. Reattach center Overflow Tube. Tuck in Tube. To form a water trap, it must be curved at approximately same position as when removed.
9. Before Sealant sets, align/adjust Flush Cover/Nozzle Assembly level to Toilet inside bowl.
10. Align Seat/Cover Assembly. Replace Hinge Posts and reattach Nuts. Tighten firmly (Fig. J).
11. Swing entire Valve/Hose Assembly upright. Holding Metal Bracket firmly to avoid bending it, slide Solenoid Valve back into slot in Bracket. Rearrange Wire Harness.

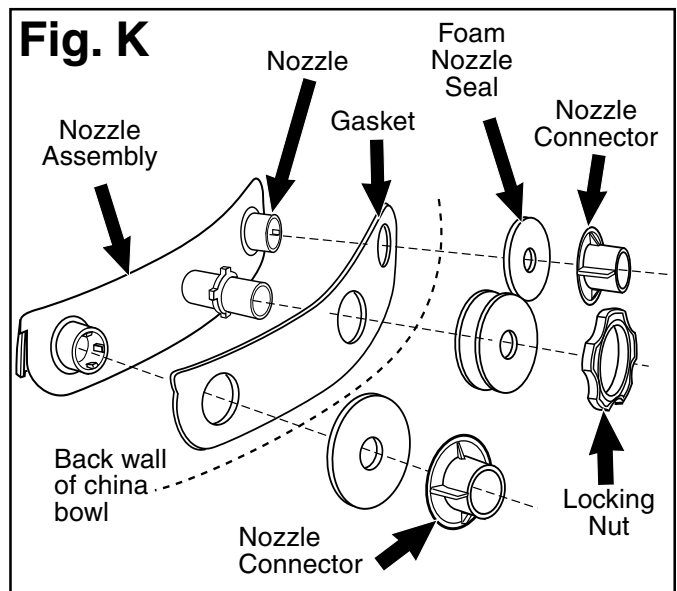
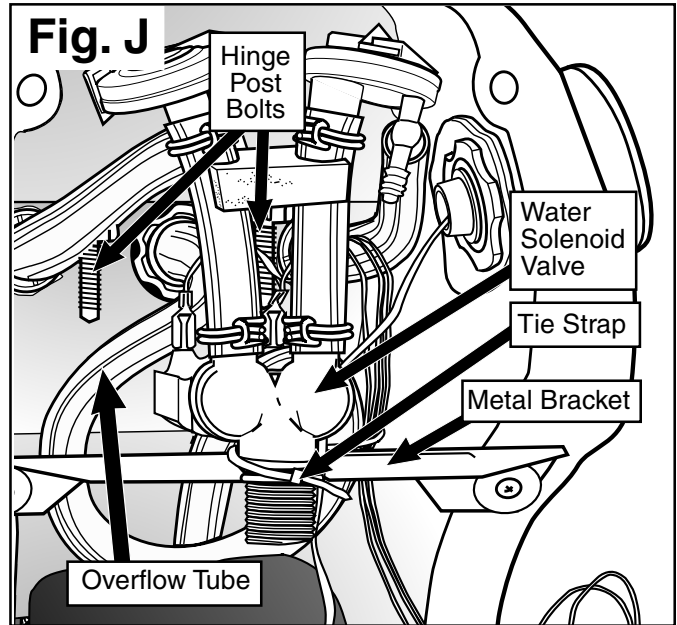

12. Reconnect Hoses to outside Flush Nozzles. Push on firmly (Fig. J).
13. Attach new Tie Strap holding Solenoid Valve to Metal Bracket (Fig. K).

To Replace Toilet To Floor

1. Secure new Closet Flange Seal, lip side up, to Toilet.
2. Position Toilet over flange.
3. Reconnect Water Supply Line.
4. Reconnect 12-volt power supply to Toilet.
5. Reconnect RV's power supply to the Toilet.
6. Turn on RV's water supply. Press Toilet flush button to close blade and to flush test.
7. Secure to floor with Lag Screws. Tighten.
8. Resecure Bolt Caps.